

S30-40FTS SERIES

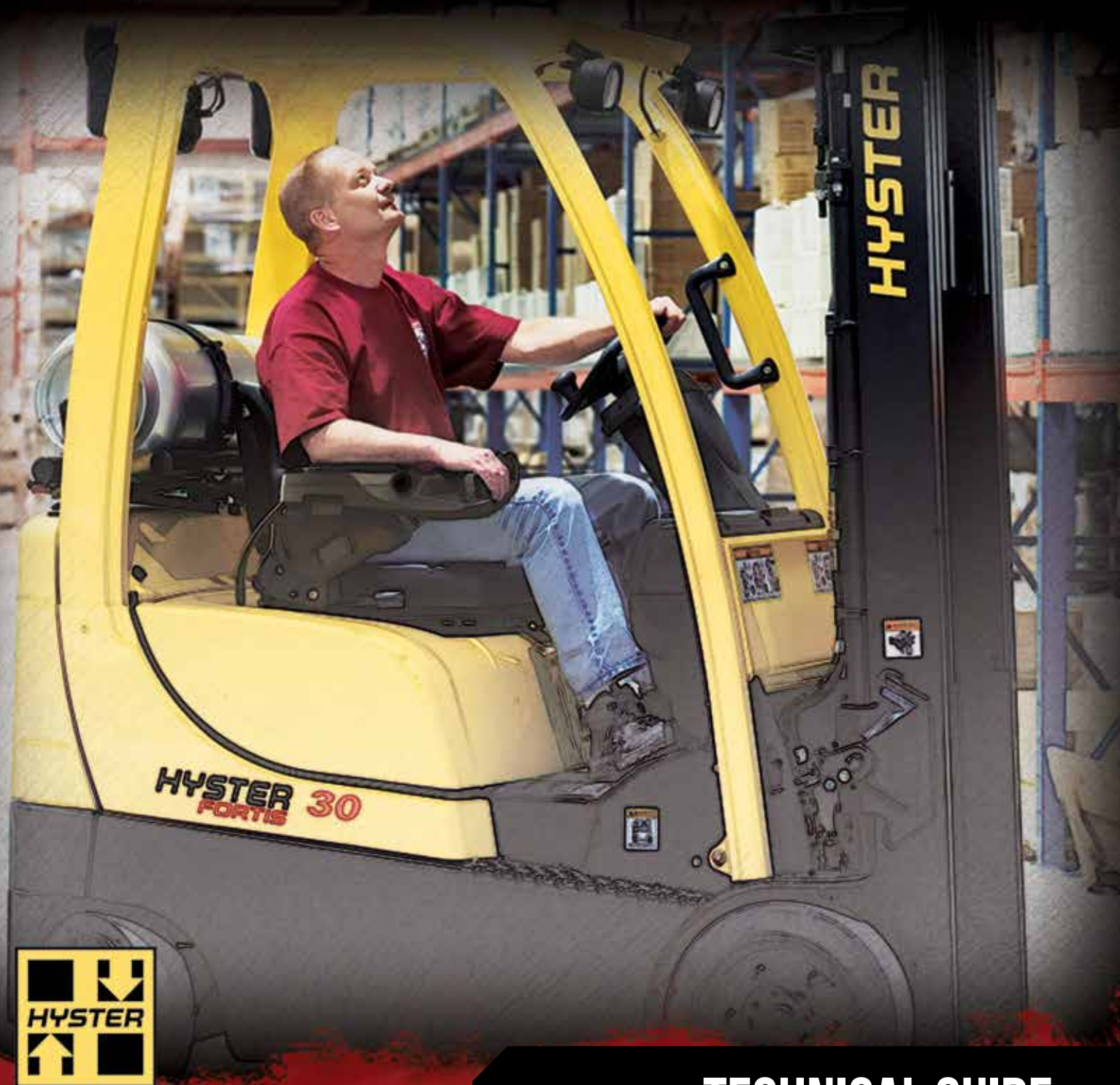

**STRONG PARTNERS.
TOUGH TRUCKS.™**

TECHNICAL GUIDE

Sit-down, Counterbalanced I.C.E. Cushion Tire

S30FT-40FTS DIMENSIONS

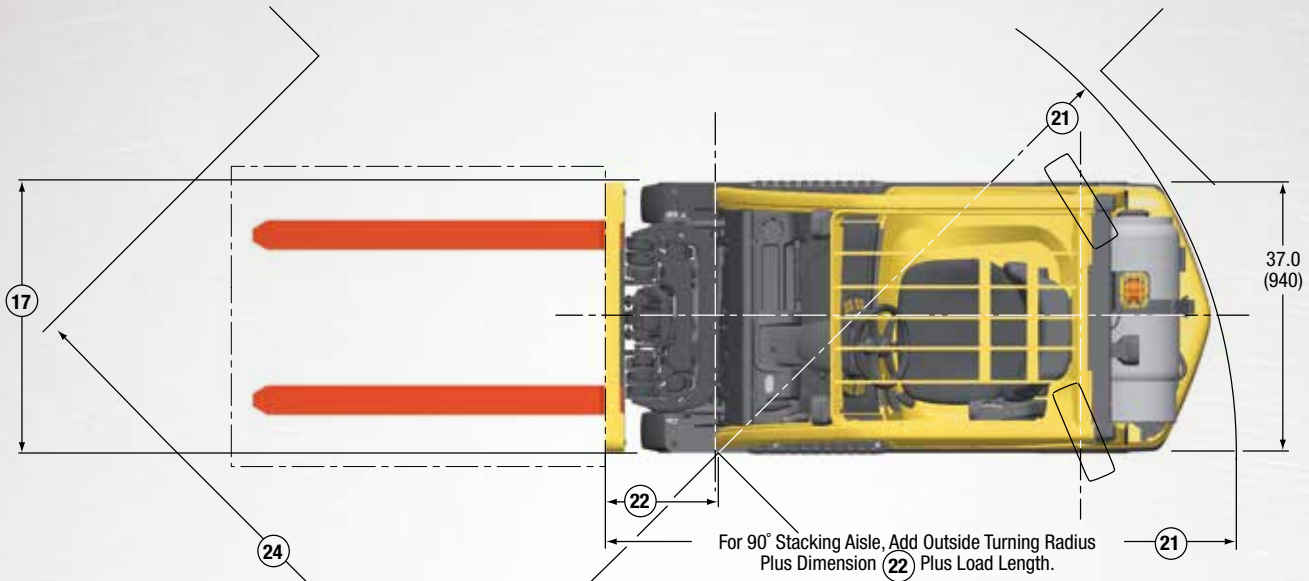

Circled dimensions correspond to the line numbers on the tabulated chart inside the technical guide. Dimensions are in inches (millimeters).

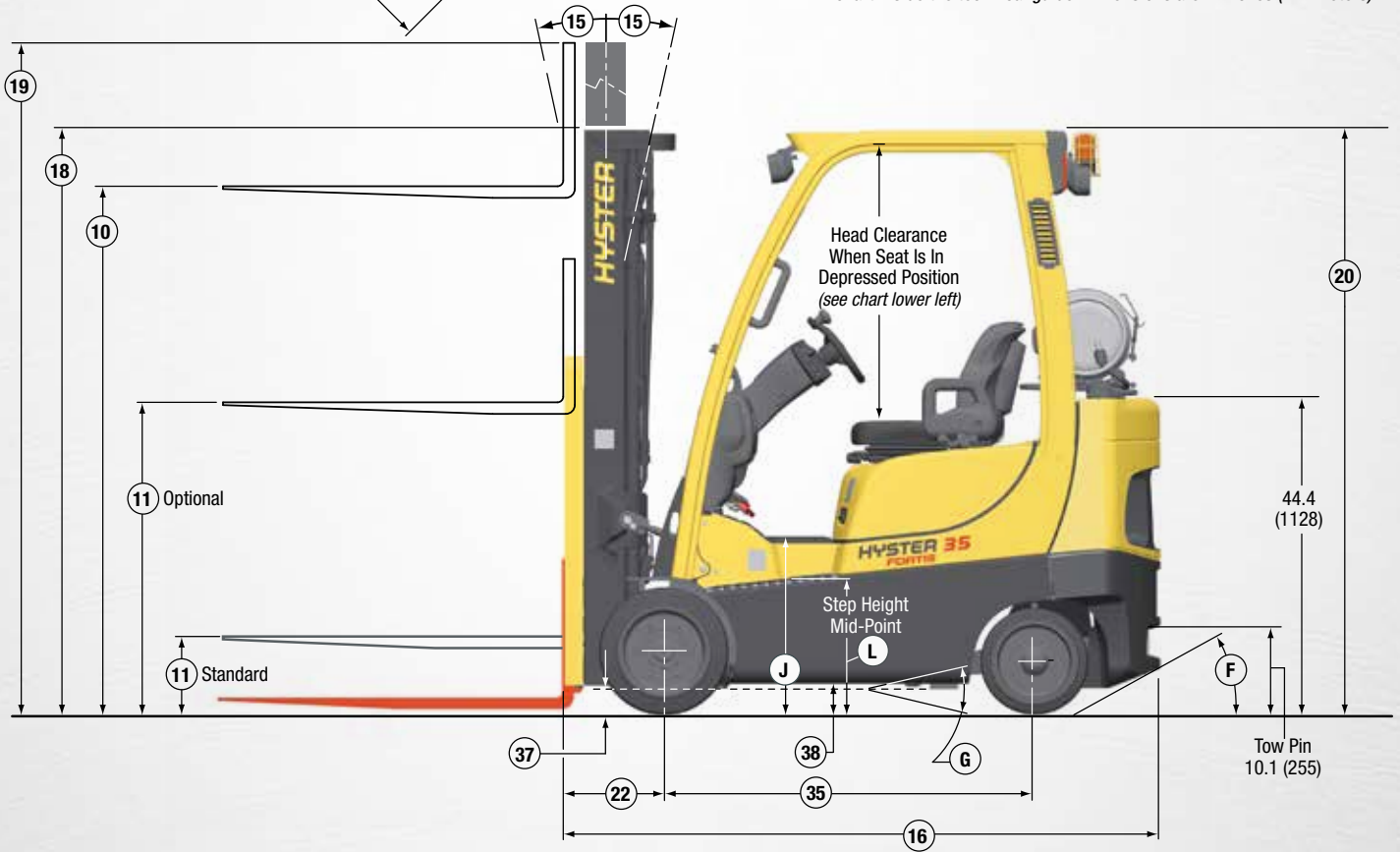

Seat Type	Standard Tall OHG	Optional Short OHG
	in (mm)	in (mm)
Non-Suspension	42.0 (1067)	39.4 (1001)
Semi-Suspension	42.5 (1079)	39.9 (1013)
Full-Suspension	41.8 (1061)	N/A
Swivel Full-Suspension	42.0 (1067)	N/A

MODEL	LIFT CAPACITY	LOAD CENTER	F	G	J	L
	lb (kg)	in (mm)	percent	percent	in (mm)	in (mm)
S30FT	3000 (1360)	24 (610)	41%	21%	25.0 (634)	19.7 (500)
S35FT	3500 (1587)	24 (610)	39%	21%	25.0 (634)	19.7 (500)
S40FTS	4000 (1814)	24 (610)	37%	21%	25.0 (634)	19.7 (500)

S30-40FTS SPECIFICATIONS

		GENERAL			
		Hyster			
		S30FT	S35FT	S40FTS	
1	Manufacturer Name	Hyster			
2	Model	S30FT	S35FT	S40FTS	
	Engine	PSI 2.0L			
3	Rated Capacity	lb (kg)	3000 (1360)	3500 (1587)	4000 (1814)
4	Load Center, Distance	in (mm)	24.0 (610)		
5	Power Type	LPG			
6	Operator Type	Sit-Down Rider			
7	Step Height	in (mm)	19.1 (485)		
8	Tire Type - Cushion, Solid, Pneumatic	Cushion			
9	Wheels, Number - Front/Rear	2x/2			
10	Lift Height, Top of Fork (TOF)	in (mm)	127 (3232)		
11	Lift Heights, Standard Limited Free Lift (LFL) w/o LBR (TOF)	in (mm)	5 (140)		
	Lift Heights, Optional Full Free Lift (FFL) w/o LBR (TOF)	in (mm)	35 (902)		
12	Standard Carriage Width	in (mm)	35.7 (907)		
13	Forks, Thickness x Width x Length	in	1.6 X 3.9 X 42.0		
	Forks, Thickness x Width x Length	(mm)	(40 X 100 X 1067)		
14	Fork Spread, Outside Dimensions	in (mm)	33.5 (850)		
15	Mast Tilt Angles, Forward/Backward	degrees	5F/5B		
16	Length To Face of Forks	in (mm)	81.6 (2074)	83.1 (2112)	84.4 (2143)
17	Overall Width, Standard Tread	in (mm)	37.0 (940)	38.8 (986)	
	Overall Width, Wide Tread	in (mm)	42.7 (1084)		
18	Height, Standard Mast - Lowered	in (mm)	82 (2080)		
19	Height, Standard Mast - Extended with LBR	in (mm)	176 (4455)		
	Height, Standard Mast - Extended without LBR	in (mm)	150 (3806)		
20	Height, Standard Overhead Guard	in (mm)	83 (2088)		
	Height, Optional Overhead Guard	in (mm)	80 (2021)		
21	Turning Radius, Minimum Outside (OTR)	in (mm)	77.0 (1955)	78.1 (1985)	
22	Length, Center of Wheel to Face of Forks	in (mm)	14.1 (358)		
23	Aisle Width, Right Angle Stack (Add Length of Load)	in (mm)	84 (2133)	85.4 (2168)	86.6 (2199)
24	Equal Aisle, 90-Degree Intersecting Aisle	in (mm)	69.8 (1773)	70.4 (1788)	70.9 (1800)
25	Travel Speed RL/NL	mph (km/h)	10.6/10.7 (17.1/17.3)		
26	Lift Speed, Standard 2-Stage LFL RL/NL	ft/min (m/s)	114/118 (.58/.60)		
	Lift Speed, Optional 2-Stage FFL RL/NL	ft/min (m/s)	102/106 (.52/.54)		
	Lift Speed, Optional 3-Stage FFL RL/NL	ft/min (m/s)	106/110 (.54/.56)		
27	Lowering Speed, Standard 2-Stage LFL RL/NL	ft/min (m/s)	100/92 (.51/.47)		
	Lowering Speed, Optional 2-Stage FFL RL/NL	ft/min (m/s)	91/73 (.46/.37)		
	Lowering Speed, Optional 3-Stage FFL RL/NL	ft/min (m/s)	94/81 (.48/.41)		
28	Drawbar Pull @ 1 mph RL/NL	lb (kg)	3152/1690 (1430/767)	3095/1579 (1404/716)	3078/1579 (1396/716)
29	Gradeability @ 1 mph RL/NL ††	%	35/27	31/24	29/22
31	Weight, Standard Truck (2-Stg. LFL) NL	lb (kg)	6159 (2794)	6591 (2990)	6971 (3162)
	Weight, Standard Truck (2-Stg. LFL) RL	lb (kg)	9159 (4155)	10091 (4577)	10971 (4976)
32	Axle Loading, Static Front/Rear NL	lb (kg)	2821/3338 (1280/1514)	2731/3859 (1239/1750)	2624/4347 (1190/1972)
	Axle Loading, Static Front/Rear RL	lb (kg)	8039/1120 (3647/508)	8820/1271 (4001/577)	9582/1389 (4346/630)
33	Tire Size, Front		18 X 6 X 12.125	18 X 7 X 12.125	
34	Tire Size, Rear		15 X 5 X 11.25		
35	Wheelbase	in (mm)	54.5 (1385)		
37	Ground Clearance, Lowest Point NL (with RL subtract -6mm)	in (mm)	3.6 (92)		
38	Ground Clearance, Center of Wheelbase NL	in (mm)	4.2 (107)		
39	Service Brake - Method of Control/Operation		Foot/Hydraulic		
40	Parking Brake - Method of Control/Operation		Hand/Mechanical		
41	Battery Type		Maintenance Free		
42	Volts/Cold Cranking Amps	v/cca	12/440		
43	Engine, Manufacturer/Model		PSI 2.0L		
44	Permanent Output	hp (kW)	44 (33)		
45	Torque @ Rated RPM	ft/lbs (kg/m)	100 (13.9) @ 1300 RPM		
46	Number of Cylinders/Displacement	No/cc (ci)	4/1997 (122)		
	Standard Speeds, Forward - Reverse		1-1		
49	Hydraulic Tank - capacity (drain & refill)	gal (liter)	8.3 (31.4)		
50	Fuel Tank Capacity (Non LP Units Only)	gal (liter)	10.2 (38.8)		
51	Auxiliary Hydraulic Pressure Relief for Attachments	PSI (Mpa)	2250 (15.4)		

NOTE: Above specifications, unless otherwise listed, are for a standard truck without optional equipment. Right Angle Stack and Equal Intersecting Aisle are calculated using a 40" wide pallet.

CERTIFICATION: These Hyster® lift trucks meet design specifications of Part II ANSI B56.1-1969, as required by OSHA Section 1910.178(a)(2) and also comply with Part III ANSI B56.1-revision in effect at time of manufacture. Certification of compliance with the applicable ANSI standards appears on the lift truck. Performance specifications are for a truck equipped as described under Standard Equipment on this Technical Guide. Performance specifications are affected by the condition of the vehicle and how it is equipped, as well as by the nature, condition of the operating area, proper service and maintenance of the vehicle. If these specifications are critical, the proposed application should be discussed with your dealer.

MAST SPECIFICATIONS AND RATED CAPACITIES

S30-40FT MAST DIMENSIONS

Max. Fork Ht. (TOF) †	Overall Lowered Ht.	Overall Extended Height		Free lift (TOF)		Approx. Total Weight of Std. Equipped Truck w/o Load		
		with LBR	w/o LBR	with LBR	w/o LBR	S30FT	S35FT	S40FTS
in (mm)	in (mm)	in (mm)	in (mm)	in (mm)	in (mm)	lbs (kg)	lbs (kg)	lbs (kg)
2-Stage Limited Free Lift (LFL) VISTA™ Mast								
83 (2132)	61 (1530)	132(3355)	107 (2706)	5 (140)	5 (140)	5960 (2704)	6394 (2900)	6774 (3073)
127 (3232)	82 (2080)	176 (4455)	150 (3806)	5 (140)	5 (140)	6159 (2794)	6591 (2990)	6971 (3162)
2-Stage Full Free Lift (FFL) VISTA™ Mast								
114 (2918)	76 (1930)	164 (4141)	138 (3492)	29 (752)	51 (1306)	6179 (2803)	6611 (2999)	6991 (3171)
126 (3218)	82 (2080)	175 (4441)	150 (3792)	35 (902)	57 (1416)	6236 (2829)	6668 (3024)	7048 (3197)
3-Stage Full Free Lift (FFL) VISTA™ Mast								
175 (4450)	78 (1980)	224 (5673)	198 (5019)	31 (802)	53 (1356)	6435 (2919)	6867 (3115)	7247 (3287)
187 (4750)	82 (2080)	236 (5973)	210 (5319)	35 (902)	57 (1456)	6479 (2939)	6911 (3135)	7291 (3307)
198 (5050)	88 (2230)	247 (6273)	222 (5619)	41 (1052)	63 (1606)	6536 (2965)	6968 (3161)	7348 (3333)
216 (5510)	94 (2380)	265 (6723)	239 (6069)	47 (1202)	69 (1756)	6655 (3019)	7087 (3215)	7467 (3387)

† Lift heights over 164.0" (4161 mm) maximum fork height are considered highlifts and require reduced capacity and restricted back tilt.
 Total approximate weights listed include mast, standard carriage, load backrest and 70 lbs. LPG tank and tank bracket.
 RL = Rated Load NL = No Load LBR = Load Backrest

RATED LOAD vs. LOAD CENTER
 STANDARD CARRIAGE
 U. S. CUSTOMARY

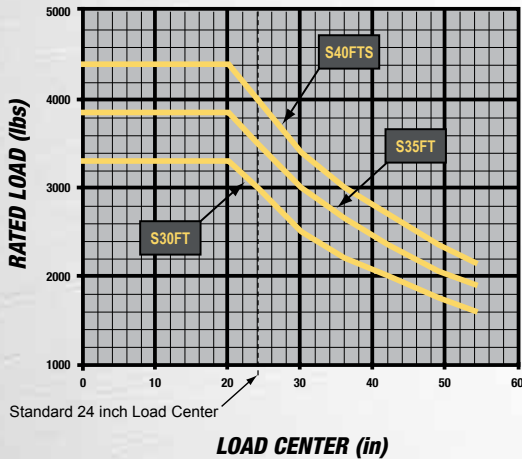

RATED LOAD vs. LOAD CENTER
 INTEGRAL CARRIAGE
 U.S. CUSTOMARY

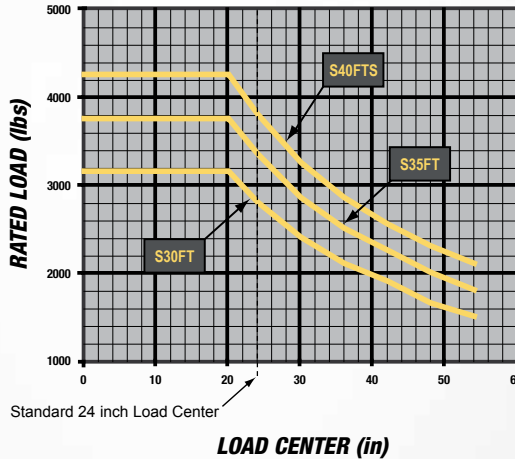

RATED LOAD vs. LOAD CENTER
 STANDARD CARRIAGE
 METRIC

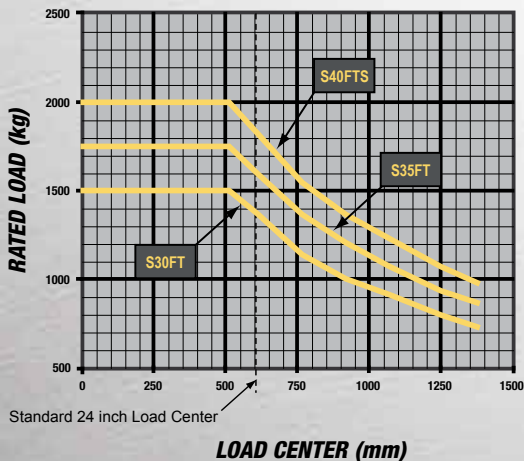

RATED LOAD vs. LOAD CENTER
 INTEGRAL CARRIAGE
 METRIC

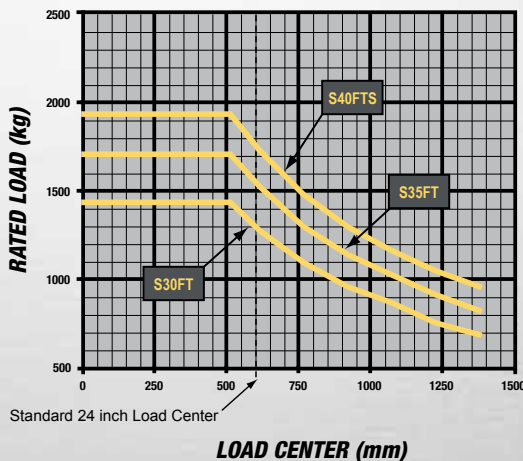

TRUCK CONFIGURATION:

- 3-Stage FFL mast at Highest Non-High Lift (HNHL) 164.0" (4161 mm) Maximum Fork Height (MFH) for S30-40FT.
- 36.0" (914 mm) Standard carriage with load backrest (LBR).
- Basic truck equipped with the PSI 2.0L LPG engine with single-speed electronic powershift transmission.

STANDARD FEATURES AND OPTIONS

STANDARD EQUIPMENT

Complete truck equipped with:

- PSI 2.0L LPG emissions compliant engine
- Electronic powershift transmission
 - Electronic inching
 - Electronic shift control
 - Neutral start switch
- Anti-restart protection
- MONOTROL® pedal
- 2-Stage limited free lift (LFL) VISTA™ mast with maximum fork height of 127" (3232 mm)
- 35.7" (907 mm) wide hook-type carriage with 48" (1219 mm) tall load backrest
- 42" (1067 mm) long forks
- 5 degrees forward and 5 degrees backward mast tilt
- 3-function valve with cowl-mounted mechanical levers
- Integrated dashboard display includes:
 - LCD Display:
 - Fuel level
 - Hour meter
 - Coolant temp
 - Clock
 - Messages
 - Service Indicator Lights:
 - Alternator
 - Transmission oil temperature
 - Engine oil pressure
 - Brake fluid level
 - Fasten seat belt
 - Low fuel level
 - Engine malfunction
 - System malfunction
 - Park brake
 - Water temp
 - Forward, reverse and neutral direction indicators
- Hydrostatic power steering
- Non-suspension vinyl seat
- Electronic horn
- Adjustable steer column
- Rubber floor mat
- High air intake
- Integral tie downs
- Operator restraint system
- Anti-clog radiator
- Single pedal inch brake
- Hyster Stability System (HSS®)
- Swing-out LPG tank bracket
- 83" (2088 mm) Overhead guard
- 12 months / 2,000 hours manufacturer's warranty
- 12 months / 4,000 hours manufacturer's powertrain warranty
- Operator's manual
- UL Classification LP

OPTIONAL EQUIPMENT

- DuraMatch™ Transmission
 - Auto deceleration system
 - Controlled power reversal feature
 - Controlled rollback on ramps
- Powertrain protection system
- Premium electronic monitoring
- High air intake with precleaner
- Keyless start (with auxiliary key switch)
- TouchPoint electro-hydraulic control with adjustable armrest
- 80" (2021 mm) short overhead guard
- Rear drive handle with horn button
- Swivel full-suspension seat – vinyl or cloth
- Semi-suspension seat - vinyl or cloth
- High-visibility non-cinch seat belt with or without interlock
- Dual inch brake pedals
- Dual side rear view mirrors
- EZXchange LPG tank bracket
- Password protection
- Audible alarm – reverse activated 82-102 dB(A) self-adjusting
- Visible alarm amber strobe light - continuous activated, overhead guard mounted
- Various light packages:
 - Two front and one rear halogen or LED work lights
 - Two front, one rear halogen or LED work light and two brake/tail/back-up high intensity LED lights
- Parts publications - printed or CD, serial number specific
- UL Classification LPS
- Integral sideshifting fork positioner
- Various tread widths available
- Operator pre-shift checklist
- Load weight display
- Impact monitor
- Integral sideshifter

STANDARD FEATURES AND OPTIONS

CAPACITY:

Model S30FT: 3000 lbs. at 24" (1360 kg at 610 mm) load center.

Model S35FT: 3500 lbs. at 24" (1587 kg at 610 mm) load center.

Model S40FTS: 4000 lbs. at 24" (1812 kg at 610 mm) load center.

Rated capacities are for trucks equipped with:

- 3-stage full free lift (FFL) VISTA™ mast to 163" (4140 mm) maximum fork height
- 35.7" (907 mm) hook-type carriage with 42" (1067 mm) long forks
- 48 (1219 mm) tall load backrest (LBR)
- Standard tread width

MASTS

Masts are available in 2-stage limited free lift (LFL) and 2- or 3-stage full free lift (FFL) VISTA™. Masts feature flush-faced, nested-channel design and full-radius, angled load rollers provides increased capacity at height while affording shorter overall length.

CARRIAGE

Carriages are hook-type, ITA Class II mounting. Overall width without load backrest (LBR) is 35.7" (907 mm); with LBR is 37" (940 mm). Minimum inside-to-inside fork spacing, center to center is 5.03" (128 mm). Maximum outside-to-outside fork spacing, center to center is 33.5" (850 mm).

FORKS

S30-40FTS series features: 1.6" x 3.9" x 36.0" to 60.0" (40 x 100 x 914 to 1525 mm) long pallet forks.

Polished and tapered forks are also available.

ENGINES

The PSI 2.0L LPG industrial engine is an EPA emissions compliant powerplant. Their configurations are specified as follows:

PSI 2.0L emissions compliant engines feature:

- 4-cylinder simple overhead cam design
- Cast iron block, aluminum cylinder heads
- Electronically controlled LPG fuel system
- Spin-on full flow oil filter
- Electronic governor
- Heavy duty air cleaner with high air intake
- Engine Control Unit (ECU)
- Three-way catalytic converter exhaust system
- 44 horsepower
- Coil cover plug ignition design
- Hydraulic adjusters
- Hyster® Variable Power Technology™ featuring two performance modes
- Twin balance shafts
- Five main bearings

TRANSMISSION

- Electronic Powershift: Single range powershift, electronic inching (requires no adjustment), electronic shift control and neutral start switch
- DuraMatch™: All of the features of the standard electronic transmission plus Auto Deceleration System, controlled power reversal, controlled rollback on ramps

COOLING SYSTEM

- Square-wave anti-clog radiator
- All radiators utilize cross-flow aluminum cores, pusher type fans and permanently lubricated water pump
- "Knife-edge" type fan shrouds that direct air flow through the counterweight air passages
- 15 psi operating system pressure

ELECTRICAL SYSTEM

- CANbus electrical system simplifies truck wiring and enhances truck dependability
- Ingress Protection Rating IP66 sealed automotive style electrical connectors
- Standardized wire routing, all wires are color coded, and marked with numbers for easy identification
- Anti-restart protection
- Vehicle System Manager (VSM) controls electrical functions, and provides onboard diagnostics, monitoring and feedback

HYDRAULIC SYSTEM

Manual hydraulic control valve & TouchPoint electro-hydraulic control valve

- Tilt and auxiliary systems have 2250 psi (15.5 MPa) relief pressure in all valve variations
- Hydraulic system is protected by a replaceable 3-micron paper element in-tank filter assembly
- Hydraulic breather filter includes an anti-splash baffle and is rated at ten micron absolute
- O-ring face seal fittings with captive O-ring grooves are used on all high pressure connections
- Emergency lowering valve allows load to be lowered in the event of battery power loss
- 100 Mesh suction line strainer

STEER AXLE / STEER SYSTEM

- Equal-area, double-ended, hydrostatic steering cylinder is mounted in cast ductile iron axle frame
- Elastomeric axle mounts absorb shock and allow lubrication free articulation
- Axle assembly utilizes synthetic boots and seals to retain lubricants and shield components against destructive grit and reduce lube points
- Wheel hubs rotate on large, tapered roller bearings
- Top spindle bearings lubricated through easy access lube fittings
- Hydrostatic steer system provides smooth, precise steering with only 4 turns lock-to-lock
- Hyster Stability System (HSS®) enhances lateral stability by limiting steer axle articulation without a compromise in traveling across various surfaces

BRAKES

- Asbestos free, self-energizing, automatically adjusting drum brake assemblies
- Single circuit master cylinder with sealed fluid reservoir and magnetic fluid level sensor
- Ratchet-type, hand-activated parking brake lever allows controlled application

OPERATOR COMPARTMENT

- Cowl-mounted hydraulic hand levers
- TouchPoint electro-hydraulic seatside mini-levers (optional)
- 12-inch textured steering wheel with spinner knob
- Automotive style foot controls with single braking/inching pedal (dual pedals optional)
- Integrated dashboard display is backlit, allowing easy visibility under all lighting conditions
- Grid-style overhead guard offers superb visibility at extended heights
- Infinitely adjustable tilt steer column
- MONOTROL® pedal controls engine speed and truck direction, freeing operator's hands to operate steering and hydraulic levers

Special attachments, equipment or accessories not listed above may be available through Applications Engineering for specific application requirements.



Hyster Company
P.O. Box 7006
Greenville, North Carolina
27835-7006
Part No. S30-40FTS/TG
1/2015 Litho in U.S.A.

Visit us online at www.hyster.com or call us at 1-800-HYSTER-1.

Hyster and  are registered trademarks of Hyster Company. Hyster products are subject to change without notice.

The Hyster Company products included in this document may be covered by US Patent 6,684,148, and other patents pending. All trucks shown with optional equipment. ©2015 Hyster Company. All rights reserved.